

8,000 • 9,000 lbs

Yale Veracitor™ GP-VX Series

This series of trucks is available in three configurations to meet and exceed your material handling application requirements. The Veracitor™ Productivity truck delivers maximum performance for medium to heavy-duty applications with state-of-the-art features and superior power. The Veracitor™ Value truck provides excellent performance for standard and medium-duty applications and is optimized for lowest hourly cost of operation. The Veracitor™ truck offers first-rate performance for standard-duty applications and is geared to minimize your cost of acquisition without compromising performance.

Yale Veracitor™ VX GM V-6 Engines feature a rigid cast iron block and main bearing caps. Nodular iron crankshaft is supported on four main bearings. Camshaft is cast iron. Hydraulic valve lifters are utilized to eliminate the need for manual adjustment. All GM engines include hardened intake and exhaust valve seats with stellite coated valves for superior durability. All engines are EPA emissions compliant and feature closed loop emissions regulation systems that continually monitor exhaust and adjust fuel/air mix as necessary. The GM engine also features an electronic throttle for precise performance and control.

Yale Veracitor™ Optional Cummins Diesel Engines features 4-valves per cylinder for improved horsepower and low end torque. The engines feature oil cooled pistons which help maintain even cylinder temperatures. Built with forged steel crankshafts for durability, the Cummins engines are fully EPA emissions compliant, featuring an electromechanical fuel system controlled by the **Intellix VSM**.

Fuel System

The standard GM LP engine uses sequential port fuel injection and a vaporizer/regulator

to convert the fuel from a liquid to a gas for vapor injection. The Engine Control Unit electronically regulates the fuel, air, and spark advance to provide the necessary torque. The engine control unit's inputs include manifold air pressure, manifold air temperature, engine coolant temperature, accelerator pedal position, throttle position, engine speed, cam signal, and oxygen sensor signal.

Transmissions

There are four transmission selections available that will handle a wide variety of material handling applications. All transmissions, including the standard electronic powershift, feature electronic inching (requires no adjustment), electronic shift control, neutral start switch, and anti-restart protection. A single pedal controls both inching and braking. Optional dual inch/brake pedals are available for operators who prefer this design. A 100 mesh suction and a 10 micron return line filtration protect the transmission from abrasive contaminants.

The Techtronix 100 and Techtronix 100X feature Auto Deceleration through the controlled application of clutch packs, and also reduce tire spin by precisely regulating engine speed during controlled power reversals. The Techtronix 100 series is available in one or two speeds. The Techtronix 200X includes all Techtronix 100 features, as well as Auto Speed Hydraulics with Automatic Inching Control. This feature automatically increases engine RPM's as hydraulic functions are actuated, while maintaining control over vehicle travel speed. The throttle response management feature provides travel speed as a direct result of pedal position, improving truck control. The Techtronix 200X has exceptional drawbar pull capabilities.

Cooling System employs a 19" (diameter) blade pusher-type fan. A permanently lubricated water pump and a high capacity, cross-flow radiator ensure rapid heat dissipation. The sealed cooling system operates at a pressure of 15 psi and includes a coolant recovery tank for visual inspection of coolant level. The Standard Electronic Powershift transmission oil cooler is integrated into the heavy-duty, anti-clog radiator and is located in the side tank. The combi-cooler radiator (standard with all Techtronix transmissions)

LP Engine Specifications

Engine LP	GM
Cylinders LP	V-6
Displacement LP	262 cu.in./4.3 liter
Torque LP	225 lb.ft. @ 2400 RPM
Horsepower LP	97.9 hp @ 2400 RPM
Air Filtration	Two Stage, Dry Type
Emission Control	Closed loop

Diesel Engine Specifications

Engine Diesel	Cummins
Cylinders Diesel	I-4
Displacement Diesel	275 cu.in./4.5 liter
Torque Diesel	225 lb.ft. @ 1300 RPM
Horsepower Diesel	77.8 hp @ 2050 RPM
Air Filtration	Two Stage, Dry Type
Emission Control	Closed loop

features an externally mounted transmission oil cooler for increased heat transfer capability. All radiators are soft-mounted for excellent durability.

Drive Axle

The drive axles are designed to withstand heavy loads and absorb shocks. The wheel hubs rotate on large tapered roller bearings. The drive shaft transmits rotational torque to the drive axle from the engine and transmission. Transmission torque is distributed through a planetary gear reduction and an industrial hypoid ring gear and pinion differential assembly.

The drive axle is a "self contained" assembly that is isolated from the transmission by the drive shaft and heavy-duty rubber isolators. The axle shafts utilize a "rolled fillet" root spline design for increased resistance to torsion stress. A magnetic sump plug is used to collect any metal particles that are circulating in the axle oil, preventing component wear.

The Yale premium brakes are single-servo hydraulic, self-energizing, and automatic adjusting drum brake assemblies. Asbestos-free brake linings are bonded to steel shoes and act against a cast iron drum. Single circuit master cylinder has sealed fluid reservoir and features a fluid level sensor which activates an indicator light located on the instrument panel. Independent, hand adjustable parking brake with push-button release has an audible alarm to indicate when the operator has left the truck without applying the parking brake.



Truck shown with optional equipment

(continued on back page)

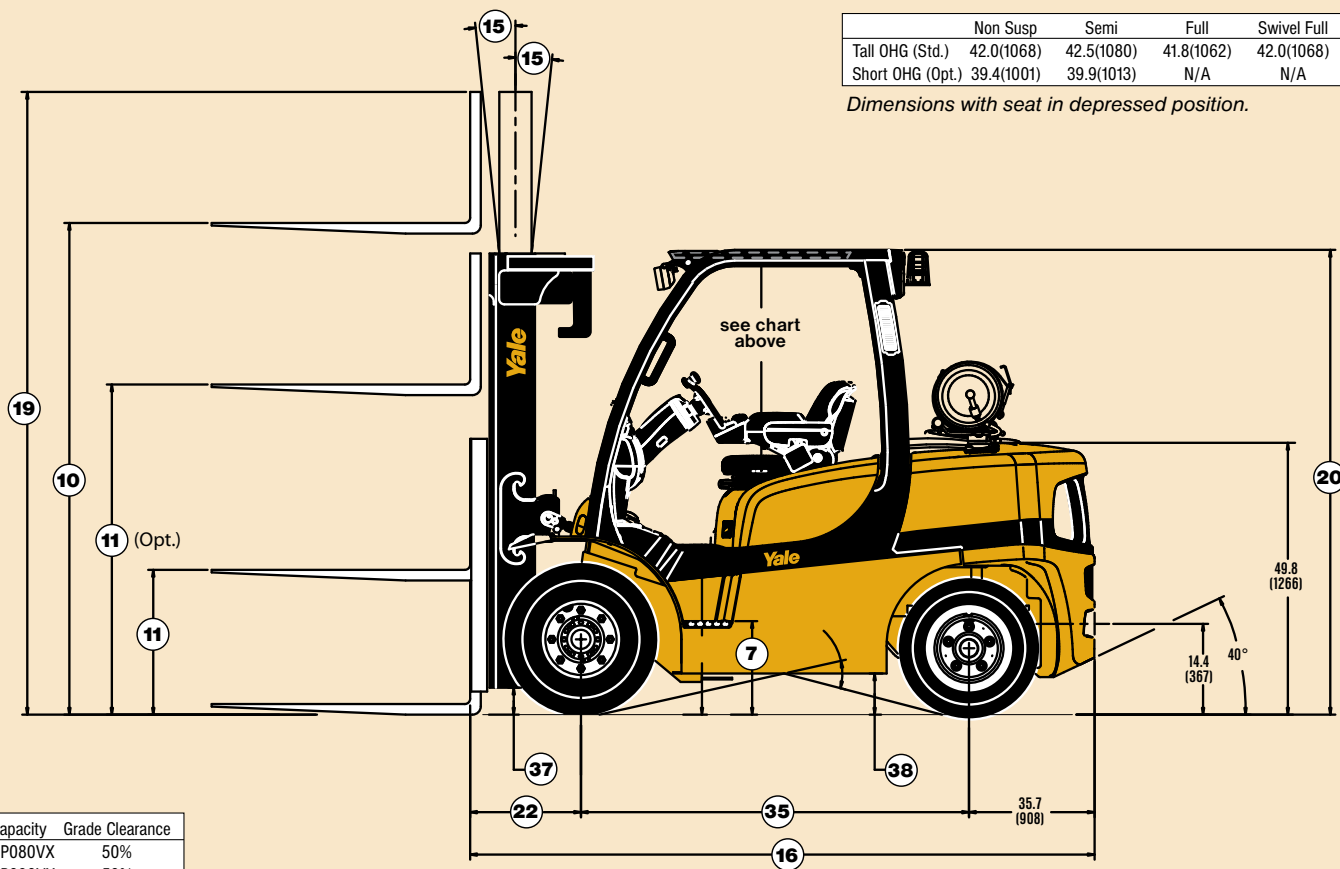
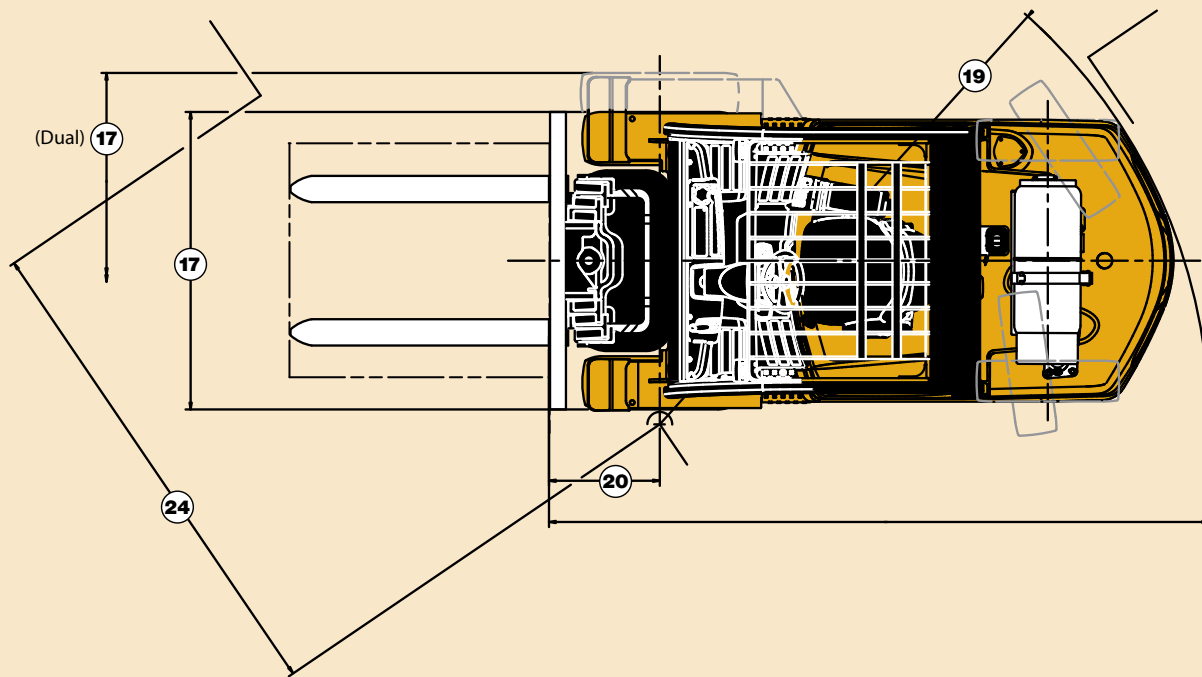

	Non Susp	Semi	Full	Swivel Full
Tall OHG (Std.)	42.0(1068)	42.5(1080)	41.8(1062)	42.0(1068)
Short OHG (Opt.)	39.4(1001)	39.9(1013)	N/A	N/A

Dimensions with seat in depressed position.

Capacity	Grade Clearance
GP080VX	50%
GP090VX	50%

Optional, oil-cooled wet disc brakes are internal to the axle for better protection against the elements. These low pedal effort brakes require no adjustments and very little maintenance, yet provide an extremely long service life.

Hydraulic Power Steering (hydrostatic steering) provides responsive control and eliminates mechanical linkages for reduced surface shock and simplified maintenance. The steering wheel is 12 inches in diameter with a textured surface grip and spinner knob, and requires only four turns lock-to-lock. The center mounted steer cylinder is located within the confines of the steer axle for protection.

Steer Axle is constructed of cast steel and is rubber shock mounted to the frame for reduced wear and vibration. The CSE (Continuous Stability Enhancement) system enhances lateral truck stability through reduced steer axle articulation, while simultaneously allowing uncompromised uneven surface travel.

Chassis designed by state-of-the-art finite element methods contains a rugged, unitized frame structure with a low step for simple entrance to the operator's compartment. Ergonomically designed overhead guard is bar type for excellent visibility and reduced noise.

Operator's Compartment features cowl mounted hydraulic control levers positioned on the right side of the steering column. Optional Accutouch minilevers or Palmtech joystick electro-hydraulic controls are integrated into the operator's right-side armrest allowing superior ergonomic actuation. Automotive-style

pedal arrangement with a large, single inch/brake pedal is standard. Tilt cylinders are located beneath the floor for uncluttered space. Rubber floor mat reduces noise and vibration. The floorplate can be removed without tools for excellent service access. Low step height and a convenient hand grip provide easy entry and exit to and from the truck.

Intellix VSM acts as a master truck controller, providing extensive monitoring and control of truck functions and systems. CANbus technology reduces wiring complexity and enables comprehensive communications between truck systems. The ergonomically positioned dash display transmits continual feedback to the operator and allows for communication of service codes. Comprehensive on-board diagnostics enable quick and easy troubleshooting. The electrical system features sealed connectors and Hall Effect sensors for superior dependability.

Hydraulic System incorporates a gear type pump with a cast iron body for quiet efficiency. The system is protected from overloads by a main relief valve for the lift circuit and a secondary relief valve for tilt and auxiliary functions. Oil is double filtered through a 100 mesh suction line strainer and 10 micron return line filter. The hydraulic tank is integrated into the frame. For Accutouch minilever or Palmtech joystick electro-hydraulic controls, an emergency lowering valve is provided to allow the load to be lowered in the event of power loss. O-ring face seal fittings are used in all high pressure hydraulic connections.

Yale Global Hi-Vis™ Masts are available in 2 Stage LFL (Limited Free Lift), 2 Stage FFL (Full Free Lift), and 3 Stage FFL models.

Mast features flush-faced design with geometrically matched, angled load roller bearings which are canted, yet provide full-face roller contact. The mast front rail flange angle coupled with the inverted "J" inner channel and three degree mast rollers significantly reduce channel and roller wear. "J-hook" mast mounting system allows for convenient mast installation and removal. A non-metallic phenolic mast pivot bushing with woven reinforcement offers high load carrying capability with outstanding durability.

Options

- Oil-cooled wet disc brakes
- 4.5L Cummins Diesel Engine
- Powertrain protection system
- Premium monitoring package
- High air intake with precleaner
- Accumulator
- Keyless start (w/auxiliary key switch)
- LED brake and back-up lights
- Headlights and rear drive lights with halogen bulbs
- Traction speed limiter
- Swing-out, drop-down EZ-Tank Bracket
- Accutouch minilever, electro-hydraulic control
- Palmtech joystick, electro-hydraulic control
- Return-to-set tilt
- Rear drive handle with horn button
- Swivel full suspension seat
- Foot Directional Control pedal
- Operator password
- Mirrors - dual side view
- Alarm-Reverse Actuated 82-102 dB(A) - Self-Adjusting
- Amber Strobe Light - Continuous Activated
- Paper Applications Kit
- 4 function (2 aux) hydraulic control valve

Standard Lift Specifications						Approx. Truck Wt. with standard configuration	
Model	O.A.H. in (mm)	Free Fork Height w/o LBR in (mm)	Max Fork Height in (mm)	Extended Height w/LBR in (mm)	Tilt Rwd/Fwd	GP80VX Lbs (Kg)	GP90VX Lbs (Kg)
2 Stage LFL	86 (2171)	5 (150)	120 (3050)	170 (4297)	10°/6°	13300 (6033)	14039 (6368)
	98 (2471)	5 (150)	143 (3650)	193 (4897)	10°/6°	13446 (6099)	14185 (6434)
	110 (2771)	5 (150)	167 (4250)	217 (5497)	10°/6°	13592 (6165)	14331 (6500)
2 Stage FFL	86 (2171)	53 (1359)	121 (3075)	171 (4322)	10°/6°	13442 (6097)	14181 (6432)
	98 (2471)	65 (1659)	144 (3675)	194 (4922)	10°/6°	13597 (6168)	14336 (6503)
3 Stage FFL	86 (2171)	53 (1359)	173 (4415)	223 (5662)	10°/6°	13977 (6340)	14715 (6675)
	90 (2271)	57 (1459)	185 (4715)	235 (5962)	10°/6°	15575 (7065)	16314 (7400)
	94 (2371)	61 (1559)	194 (4950)	244 (6197)	10°/6°	15650 (7099)	16389 (7434)
	98 (2471)	65 (1659)	206 (5250)	256 (6497)	10°/6°	15725 (7133)	16464 (7468)
	102 (2571)	69 (1759)	218 (5550)	268 (6797)	10°/6°	15803 (7168)	16541 (7503)

Truck performance may be affected by the condition of the vehicle, how it is equipped and the application. Consult your Yale Industrial Truck Dealer if any of the information shown is critical to your application. Specifications are subject to change without notice.

This truck meets all design specifications of ANSI B56.1 Safety Standard for Powered Industrial Trucks at the time of manufacture. Classified by Underwriters' Laboratories, Inc. as to fire hazard only.

The Yale products included in this document may be covered by US patent 6,684,148 and other patents pending.

Yale, the Yale Logo, Veracitor™ VX and Yale Global Hi Vis™ Mast are trademarks or registered trademarks of Yale Material Handling Corporation in the United States and other countries.

Note: GP80-90VX has standard 250 x 15-20 PR drive tires @ 55.2 inch (1402 mm) overall width.



Yale Materials Handling Corporation
P.O. Box 7367, Greenville, North Carolina 27835-7367

xxxx-x-06/06-xxx
Copyright 2006
Yale Materials Handling Corporation
Printed in U.S.A.

Manufactured in our own ISO 9001:2000 Registered Facilities

GENERAL	1	Manufacturer	Manufacturer Name	
	2	Model	Manufacturer Designation	
			Transmission	
			Engine	
	3	Capacity	Rated Capacity	lb. (kg)
	4	Load Center	Distance	in. (mm)
	5	Power Type	Gasoline, LPG, Diesel	
	6	Operator Type	Pedestrian, Stand-on, Seated Rider	
	7	Step Height		in. (mm)
8	Tire Type	Cushion, Solid, Pneumatic, etc.		
9	Wheels	Number – Front/Rear		
DIMENSIONS	10	Lift Heights with 2-Stage Mast	Lift Height (Top of Fork)	in. (mm)
	11		Standard Free Lift (Top of Fork) with LBR	in. (mm)
			Optional Free Lift w/LBR (Top of Fork)–86/120" Mast	in. (mm)
	12	Std. Carriage Width	Standard Carriage Width	in. (mm)
	13	Forks	Thickness/Width/Length	in. (mm)
	14	Fork Spread	Outside Dimensions	in. (mm)
	15	Tilt of Mast	Forward/Backward	degrees
	16	Dimensions	Length To Face of Forks	in. (mm)
	17		Overall Width Narrow/Wide Tread	in. (mm)
	18		Overall Width Dual Tread	in. (mm)
	19		Height with Standard Mast in Lowered Position	in. (mm)
	20		Standard Mast Extended Height without/with LBR	in. (mm)
			Height of Standard Overhead Guard	in. (mm)
		Height of Optional Overhead Guard	in. (mm)	
		Height of Optional Cab	in. (mm)	
21	Turning Radius	Minimum Outside (OTR)	in. (mm)	
22	Load Distance	Center of Wheel to Face of Forks/Front Overhang	in. (mm)	
23	Aisle Width	Right Angle Stack (Add Length of Load)	in. (mm)	
24	Equal Aisle	90 Degree Intersecting Aisle (W=42in., L=48in.)	in. (mm)	
PERFORMANCE	25	Speeds	Travel Speed – With Load/No Load	mph (km/h)
	26		Lift Speed – With Load/No Load: Std Mast 2 stg LFL	ft./min (m/s)
			Lift Speed – With Load/No Load: Opt 2 Stg FFL Mast	
			Lift Speed – With Load/No Load: Opt 3 FFL Stg Mast	
	27		Lowering Speed – With Load/No Load Std Mast 2 Stg LFL	
			Lowering Speed – With Load/No Load Opt 2 Stg FFL Mast	
			Lowering Speed – With Load/No Load Opt 3 Stg FFL Mast	
	28	Drawbar Pull	With Load/No Load Maximum	
	With Load/No Load @ 1 mph		lb. (kg.)	
	With Load/No Load @ 3 mph		lb. (kg.)	
29	Gradeability	With Load/No Load @ 1 mph	%	
		With Load/No Load @ 3 mph	%	
WT.	31	Weight	Std Truck, Unloaded	lb. (kg.)
	32	Axle Loads	With Load – Front/Rear	lb. (kg.)
			No Load – Front/Rear	lb. (kg.)
WHEELS & TIRES	33	Tire Size	Front	
	34		Rear	
	35	Wheelbase	Distance	in. (mm)
	37	Ground Clearance	No Load at Lowest Point (w/rated load)	in. (mm)
	38		No Load at Center of Wheelbase	in. (mm)
	39	Brakes	Brakes Service – Method of Control/Operation	
40	Brakes Park – Method of Control/Operation			
TRANS. & POWER UNIT	41	Battery	Type	
	42		Volts/Cold Cranking Amps	v/cca
	43	ICE Engine	Manufacturer/Model	
	44		Output	hp (KW)
	45		Torque @ Rated RPM	ft Lbs. (kg/m)
	46		Number of Cylinders/Displacement	No. cc (ci)
	47	Transmission	With ICE Drive	Type
			Number of Standard Speeds Fwd-Rev/Opt Speeds Fwd-Rev	Speeds
	48	Fuel Tank	Capacity	gal (liters)
49	Aux Hydraulic Pressure Relief Setting	Pressure Relief Setting for Auxilliary Attachments	PSI (Mpa)	

	Standard Electronic Powershift (Single-Speed)	Techtronix 100 (Single-Speed)
	GM 4.3L	GM 4.3L
	8000 (4000)	8000 (4000)
	24 (500)	24 (500)
	LP	LP
	Seated Rider	Seated Rider
	17.4 (441)	17.4 (441)
	Pneumatic	Pneumatic
	2/2	2/2
	120 (3050)	120 (3050)
	5 (150)	5 (150)
	36 (924)	36 (924)
	48 (1219)	48 (1219)
	2.0 X 5.0 X 48 (50 X 125 X 1219)	2.0 X 5.0 X 48 (50 X 125 X 1219)
	43.5 (1105)	43.5 (1105)
	6F/10B	6F/10B
	115.9 (2945)	115.9 (2945)
	55.2/58.5 (1402/1486)	55.2/58.5 (1402/1486)
	69.8 (1773)	69.8 (1773)
	86 (2171)	86 (2171)
	170/151 (4297/3815)	170/151 (4297/3815)
	89 (2258)	89 (2258)
	87 (2191)	87 (2191)
	90 (2276)	90 (2276)
	101.2 (2570)	101.2 (2570)
	20.6 (522)	20.6 (522)
	121.7 (3092)	121.7 (3092)
	91.3 (2320)	91.3 (2320)
	11.2/11.7 (18.0/18.8)	11.2/11.7 (18.0/18.8)
	120.1/122.0 (.61/.62)	120.1/122.0 (.61/.62)
	106.3/108.3 (.54/.55)	106.3/108.3 (.54/.55)
	112.2/114.2 (.57/.58)	112.2/114.2 (.57/.58)
	108.3/92.5 (.55/.47)	108.3/92.5 (.55/.47)
	98.4/70.9 (.50/.36)	98.4/70.9 (.50/.36)
	104.3/86.6 (.53/.44)	104.3/86.6 (.53/.44)
	6512/2125 (2954/964)	6512/2125 (2954/964)
	5831/2125 (2645/964)	5831/2125 (2645/964)
	4553/2125 (2065/964)	4553/2125 (2065/964)
	26.7/15.6	26.7/15.6
	23.0/22.6	23.0/22.6
	13300 (6033)	13300 (6033)
	18660/2641 (8464/1198)	18660/2641 (8464/1198)
	5739/7560 (2603/3429)	5739/7560 (2603/3429)
	250x15-20PR	250x15-20PR
	7.00X12-14PR	7.00X12-14PR
	72.0 (1830)	72.0 (1830)
	5.9 (151)	5.9 (151)
	7.6 (194)	7.6 (194)
	Foot/Hydraulic	Foot/Hydraulic
	Hand/Mechanical	Hand/Mechanical
	Maintenance Free	Maintenance Free
	12/475	12/475
	GM LP	GM LP
	97.9 (73) @ 2400 RPM	97.9 (73) @ 2400 RPM
	225 (305) @ 2400 RPM	225 (305) @ 2400 RPM
	V-6/4302 (262)	V-6/4302 (262)
	Powershift	Electronically Controlled Powershift
	1-1	1-1
	N/A	N/A
	2250 (155)	2250 (155)

Yale					
Veracitor GP80VX					
Techtronix 100X (2-Speed)	Techtronix 200X (2-Speed)	Standard Electronic Powershift (Single-Speed)	Techtronix 100 (Single-Speed)	Techtronix 100X (2-Speed)	Techtronix 200X (2-Speed)
GM 4.3L	GM 4.3L	Cummins	Cummins	Cummins	Cummins
8000 (4000)	8000 (4000)	8000 (4000)	8000 (4000)	8000 (4000)	8000 (4000)
24 (500)	24 (500)	24 (500)	24 (500)	24 (500)	24 (500)
LP	LP	Diesel	Diesel	Diesel	Diesel
Seated Rider	Seated Rider	Seated Rider	Seated Rider	Seated Rider	Seated Rider
17.4 (441)	17.4 (441)	17.4 (441)	17.4 (441)	17.4 (441)	17.4 (441)
Pneumatic	Pneumatic	Pneumatic	Pneumatic	Pneumatic	Pneumatic
2/2	2/2	2/2	2/2	2/2	2/2
120 (3050)	120 (3050)	120 (3050)	120 (3050)	120 (3050)	120 (3050)
5 (150)	5 (150)	5 (150)	5 (150)	5 (150)	5 (150)
36 (924)	36 (924)	36 (924)	36 (924)	36 (924)	36 (924)
48 (1219)	48 (1219)	48 (1219)	48 (1219)	48 (1219)	48 (1219)
2.0 X 5.0 X 48 (50 X 125 X 1219)	2.0 X 5.0 X 48 (50 X 125 X 1219)	2.0 X 5.0 X 48 (50 X 125 X 1219)	2.0 X 5.0 X 48 (50 X 125 X 1219)	2.0 X 5.0 X 48 (50 X 125 X 1219)	2.0 X 5.0 X 48 (50 X 125 X 1219)
43.5 (1105)	43.5 (1105)	43.5 (1105)	43.5 (1105)	43.5 (1105)	43.5 (1105)
6F/10B	6F/10B	6F/10B	6F/10B	6F/10B	6F/10B
115.9 (2945)	115.9 (2945)	115.9 (2945)	115.9 (2945)	115.9 (2945)	115.9 (2945)
55.2/58.5 (1402/1486)	55.2/58.5 (1402/1486)	55.2/58.5 (1402/1486)	55.2/58.5 (1402/1486)	55.2/58.5 (1402/1486)	55.2/58.5 (1402/1486)
69.8 (1773)	69.8 (1773)	69.8 (1773)	69.8 (1773)	69.8 (1773)	69.8 (1773)
86 (2171)	86 (2171)	86 (2171)	86 (2171)	86 (2171)	86 (2171)
170/151 (4297/3815)	170/151 (4297/3815)	170/151 (4297/3815)	170/151 (4297/3815)	170/151 (4297/3815)	170/151 (4297/3815)
89 (2258)	89 (2258)	89 (2258)	89 (2258)	89 (2258)	89 (2258)
87 (2191)	87 (2191)	87 (2191)	87 (2191)	87 (2191)	87 (2191)
90 (2276)	90 (2276)	90 (2276)	90 (2276)	90 (2276)	90 (2276)
101.2 (2570)	101.2 (2570)	101.2 (2570)	101.2 (2570)	101.2 (2570)	101.2 (2570)
20.6 (522)	20.6 (522)	20.6 (522)	20.6 (522)	20.6 (522)	20.6 (522)
121.7 (3092)	121.7 (3092)	121.7 (3092)	121.7 (3092)	121.7 (3092)	121.7 (3092)
91.3 (2320)	91.3 (2320)	91.3 (2320)	91.3 (2320)	91.3 (2320)	91.3 (2320)
14.6/15.2 (23.5/24.5)	13.8/14.4 (22.2/23.2)	11.9/12.4 (19.2/20.0)	11.9/12.4 (19.2/20.0)	13.7/14.3 (22.0/23.0)	13.0/13.5 (20.9/21.7)
120.1/122.0 (.61/.62)	120.1/122.0 (.61/.62)	118.1/129.9 (.60/.66)	118.1/129.9 (.60/.66)	118.1/129.9 (.60/.66)	118.1/129.9 (.60/.66)
106.3/108.3 (.54/.55)	106.3/108.3 (.54/.55)	104.3/114.2 (.53/.58)	104.3/114.2 (.53/.58)	104.3/114.2 (.53/.58)	104.3/114.2 (.53/.58)
112.2/114.2 (.57/.58)	112.2/114.2 (.57/.58)	110.2/114.2 (.56/.58)	110.2/114.2 (.56/.58)	110.2/114.2 (.56/.58)	110.2/114.2 (.56/.58)
108.3/92.5 (.55/.47)	108.3/92.5 (.55/.47)	108.3/92.5 (.55/.47)	108.3/92.5 (.55/.47)	108.3/92.5 (.55/.47)	108.3/92.5 (.55/.47)
98.4/70.9 (.50/.36)	98.4/70.9 (.50/.36)	98.4/70.9 (.50/.36)	98.4/70.9 (.50/.36)	98.4/70.9 (.50/.36)	98.4/70.9 (.50/.36)
104.3/86.6 (.53/.44)	104.3/86.6 (.53/.44)	104.3/86.6 (.53/.44)	104.3/86.6 (.53/.44)	104.3/86.6 (.53/.44)	104.3/86.6 (.53/.44)
7000/2125 (3175/964)	7000/2125 (3175/964)	6476/2125 (2937/964)	6476/2125 (2937/964)	7000/2125 (3175/964)	7000/2125 (3175/964)
6856/2125 (3110/964)	6904/2125 (3132/964)	5741/2125 (2604/964)	5741/2125 (2604/964)	6895/2125 (3128/964)	6975/2125 (3164/964)
5000/2125 (2268/964)	5150/2125 (2336/964)	4300/2125 (1950/964)	4300/2125 (1950/964)	5000/2125 (2268/964)	5125/2125 (2325/964)
31.9/15.6	32.1/15.6	26.3/15.6	26.3/15.6	32.1/15.6	32.5/15.6
25.0/22.6	28.0/22.6	17.0/22.6	17.0/22.6	19.0/22.6	19.0/22.6
13300 (6033)	13300 (6033)	13576 (6158)	13576 (6158)	13576 (6158)	13576 (6158)
18660/2641 (8464/1198)	18660/2641 (8464/1198)	18785/2791 (8521/1266)	18785/2791 (8521/1266)	18785/2791 (8521/1266)	18785/2791 (8521/1266)
5739/7560 (2603/3429)	5739/7560 (2603/3429)	5864/7709 (2660/3497)	5864/7709 (2660/3497)	5864/7709 (2660/3497)	5864/7709 (2660/3497)
250x15-20PR	250x15-20PR	250x15-20PR	250x15-20PR	250x15-20PR	250x15-20PR
7.00X12-14PR	7.00X12-14PR	7.00X12-14PR	7.00X12-14PR	7.00X12-14PR	7.00X12-14PR
72.0 (1830)	72.0 (1830)	72.0 (1830)	72.0 (1830)	72.0 (1830)	72.0 (1830)
5.9 (151)	5.9 (151)	5.9 (151)	5.9 (151)	5.9 (151)	5.9 (151)
7.6 (194)	7.6 (194)	7.6 (194)	7.6 (194)	7.6 (194)	7.6 (194)
Foot/Hydraulic	Foot/Hydraulic	Foot/Hydraulic	Foot/Hydraulic	Foot/Hydraulic	Foot/Hydraulic
Hand/Mechanical	Hand/Mechanical	Hand/Mechanical	Hand/Mechanical	Hand/Mechanical	Hand/Mechanical
Maintenance Free	Maintenance Free	Maintenance Free	Maintenance Free	Maintenance Free	Maintenance Free
12/475	12/475	12/900	12/900	12/900	12/900
GM LP	GM LP	Cummins Diesel	Cummins Diesel	Cummins Diesel	Cummins Diesel
97.9 (73) @ 2400 RPM	97.9 (73) @ 2400 RPM	77.8 (58) @ 2050 RPM	77.8 (58) @ 2050 RPM	77.8 (58) @ 2050 RPM	77.8 (58) @ 2050 RPM
225 (305) @ 2400 RPM	225 (305) @ 2400 RPM	225 (305) @ 1300 RPM	225 (305) @ 1300 RPM	225 (305) @ 1300 RPM	225 (305) @ 1300 RPM
V-6/4302 (262)	V-6/4302 (262)	I-4/4516 (275)	I-4/4516 (275)	I-4/4516 (275)	I-4/4516 (275)
Electronically Controlled Powershift	Electronically Controlled Powershift	Powershift	Electronically Controlled Powershift	Electronically Controlled Powershift	Electronically Controlled Powershift
2-1	2-1	1-1	1-1	2-1	2-1
N/A	N/A	20.9 (79)	20.9 (79)	20.9 (79)	20.9 (79)
2250 (155)	2250 (155)	2250 (155)	2250 (155)	2250 (155)	2250 (155)

Standard Electronic Powershift (Single-Speed)
GM 4.3L
9000 (4500)
24 (500)
LP
Seated Rider
17.4 (441)
Pneumatic
2/2
120 (3050)
6 (160)
36 (924)
48 (1219)
2.0 X 5.0 X 48 (50 X 125 X 1219)
43.5 (1105)
6F/10B
118.0 (2997)
55.2/58.5 (1402/1486)
69.8 (1773)
86 (2171)
170/151 (4297/3815)
89 (2258)
87 (2191)
90 (2276)
103.1 (2619)
20.6 (522)
123.7 (3141)
92.3 (2345)
11.2/11.7 (18.0/18.8)
120.1/122.0 (.61/.62)
106.3/108.3 (.54/.55)
112.2/114.2 (.57/.58)
108.3/92.5 (.55/.47)
88.6/63.0 (.45/.32)
104.3/76.8 (.53/.39)
6480/2237 (2939/1015)
5800/2237 (2631/1015)
4525/2237 (2053/1015)
24.6/15.6
18.6/15.6
14039 (6368)
20051/2989 (9095/1356)
5569/8470 (2526/3842)
250x15-20PR
7.00X12-14PR
72.0 (1830)
5.9 (151)
7.6 (194)
Foot/Hydraulic
Hand/Mechanical
Maintenance Free
12/475
GM LP
97.9 (73) @ 2400 RPM
225 (305) @ 2400 RPM
V-6/4302 (262)
Powershift
1-1
N/A
2250 (155)

