



**STRONG PARTNERS. TOUGH TRUCKS.**

## **Laden Container Handling Trucks H40.00-50.00XM-16CH**

Nominal Capacity: 40 000-50 000kg @ 1600 mm



# Technical Data

		<b>HYSTER</b>		<b>HYSTER</b>			
WEIGHTS & CHARACTERISTICS	1.1	Manufacturer	HYSTER		HYSTER		
	1.2	Model designation	H 40.00XM- 16CH		H 44.00XM- 16CH		
	1.3	Power: Battery, Diesel, LPG, Electric mains	Diesel		Diesel		
	1.4	Operation: manual, pedestrian, stand, seat, orderpicker	seat		seat		
	1.5	Load capacity	Q ( kg )	37,100	33,400	39,900	35,950
	1.6	Load centre – reach retracted/extended	c (mm)	1,400	1,610	1,400	1,610
	1.8	Load distance	x (mm)	870		870	
	1.9	Wheelbase	y (mm)	5,900		5,900	
	2.1	Unladen weight	kg	57,650		59,650	
2.2	Axle loading with load, front / rear	kg	89,523	5,226	93,677	5,892	
2.3	Axle loading without load, front / rear	kg	38,179	19,470	38,430	21,219	
WHEELS & TYRES	3.1	L=pneumatics, V=solids, SE=pneumatic-shaped solids	Pneumatic		Pneumatic		
	3.2	Tyres size, front	18.00 x 25 36PR		18.00 x 25 36PR		
	3.3	Tyres size, rear	18.00 x 25 36PR		18.00 x 25 36PR		
	3.31	Tyres size, rear (optional)	16.00 x 25 28PR		16.00 x 25 28PR		
	3.5	Number of wheels, front / rear ( X driven )	x 4 / 2		x 4 / 2		
	3.6	Track width, front	b <sup>10</sup> (mm)	3,030		3,030	
	3.7	Track width, rear	b <sup>11</sup> (mm)	3,075		3,075	
	4.1	Mast tilt : forward / backwards	degree	6°	10°	6°	10°
	4.2	Height of mast lowered	h <sup>1</sup> (mm)	6,476		6,476	
	4.3	Minimum height of twistlocks (mast lowered)	h <sup>13</sup> (mm)	2,280		2,280	
DIMENSIONS	4.4	Mast Lifting height	h <sup>3</sup> (mm)	7,010	3 high	7,010	3 high
	4.5	Maximum height extended (to top of spreader)	h <sup>4</sup> (mm)	10,576		10,576	
	4.7	Cab height	h <sup>6</sup> (mm)	4,660		4,660	
	4.8	Seat height	h <sup>7</sup> (mm)	3,525		3,525	
	4.19	Overall length including spreader	l <sup>1</sup> (mm)	10,338		10,338	
	4.20	Length without spreader	l <sup>2</sup> (mm)	7,718		7,718	
	4.21	Overall truck width	b <sup>2</sup> (mm)	4,200		4,200	
	4.23	Container spreader		ISO 20' - 40'		ISO 20' - 40'	
	4.23.1	Spreader sideways articulation	degree	+/- 2,5°	mechanically	+/- 2,5°	mechanically
	4.24	Overall width with spreader in 20' position	b <sup>3</sup> (mm)	6,100		6,100	
	4.28	Slew and reach of spreader	l <sup>4</sup> (mm)	+/- 4,5 degrees / 210 mm		+/- 4,5 degrees / 210 mm	
	4.30	Side shift movement of spreader	b <sup>8</sup> (mm)	432 (+/- 216)		432 (+/- 216)	
	4.31	Ground clearance, under mast with load	m <sup>1</sup> (mm)	350		350	
	4.32	Ground clearance, centre of wheelbase	m <sup>2</sup> (mm)	370		370	
	4.33	Stacking aisle, 20' / 40', without operating clearance	Ast (mm)	11,430	14,045	11,430	14,045
	4.33	Stacking aisle, 20' / 40', with 200 mm operating clearance	Ast (mm)	11,630	14,245	11,630	14,245
	4.33	Stacking aisle, 20' / 40', with 10% operating clearance	Ast (mm)	12,575	15,450	12,575	15,450
4.35	Turning radius	Wa (mm)	7,925		7,925		
4.36	Distance – centre of truck to centre of inner turning cycle	b <sup>13</sup> (mm)	3,375		3,375		
PERFORMANCE	5.1	Travel speed with / without load	km/h	20	23	20	23
	5.2	Lifting speed with / without load	m/s	0.24	0.28	0.24	0.28
	5.3	Lowering speed with / without load	m/s	0.50	0.50	0.50	0.50
	5.5	Drawbar pull with / without load, maximum †	kN	360	266	360	282
	5.7	Gradeability with / without load, maximum ◆	%	41	49	37	45
	5.10	Service brake		wet disc brakes		wet disc brakes	
ENGINE	7.1	Engine manufacturer / type	Cummins	QSM 11	Cummins	QSM 11	
	7.2	Maximum engine output	kW	224 (300HP)		224 (300HP)	
	7.3	at engine speed	min <sup>-1</sup>	1,800 - 2,100		1,800 - 2,100	
	7.4	Number of cylinders / displacement	/ cm <sup>3</sup>	6	10,800	6	10,800
	7.5	Fuel consumption average	l/h	19		19	
OTHERS	8.1	Drive control	Automatic 4-speed		Automatic 4-speed		
	8.2	Working pressure for attachments	bar	245		245	
	8.3	Oil flow for attachments	l/min	90		90	
	8.4	Average noise level at driver's ear	dB (A)	73		73	
	8.5	Towing coupling model / type		no		no	

## EQUIPMENT & WEIGHTS

Weights (line 2.1) are based on the following specifications: Complete truck with cab, pneumatic tyres, mast as specified, dedicated carriage and 20' – 40' spreader.

## NOTE:

Specifications are affected by the conditions of the vehicle and how it is equipped, as well as the nature and condition of the operating area. If these specifications are critical, the proposed application should be discussed with your dealer

◆ Gradeability figures (line 5.7) are provided for comparison of tractive performance, but are not intended to endorse the operation of the vehicle on the stated inclines. Follow instructions in the operating manual regarding operation on inclines.

HYSTER		HYSTER		1.1
H 48.00XM- 16CH		H 50.00XM- 16CH		1.2
Diesel seat		Diesel seat		1.3
40,000		40,000		1.4
1,400	1,610	1,415	1,625	1.5
870		885		1.6
5,900		5,900		1.7
64,590		70,150		1.8
96,987	7,600	99,020	11,132	1.9
41,629	22,958	43,561	26,591	2.1
Pneumatic		Pneumatic		2.2
18.00 x 25 36PR		18.00 x 25 40PR		2.3
18.00 x 25 36PR		18.00 x 25 40PR		2.4
16.00 x 25 28PR		not 16.00 x 25		2.5
x 4 / 2		x 4 / 2		2.6
3,030		3,030		2.7
3,075		3,075		2.8
6°		6°		2.9
10°		10°		3.0
7,847		7,847		3.1
2,280		2,280		3.2
9,755		9,755		3.3
4 high		4 high		3.4
13,320		13,320		3.5
4,660		4,660		3.6
3,525		3,525		3.7
10,338		10,338		3.8
7,718		7,718		3.9
4,200		4,200		4.0
ISO 20' - 40'		ISO 20' - 40'		4.1
+/- 2,5° mechanically		+/- 2,5° mechanically		4.2
6,100		6,100		4.3
+/- 4,5 degrees / 210 mm		+/- 4,5 degrees / 210 mm		4.4
432 (+/- 216)		432 (+/- 216)		4.5
350		350		4.6
370		370		4.7
11,430	14,045	11,430	14,045	4.8
11,630	14,245	11,630	14,245	4.9
12,575	15,450	12,575	15,450	5.0
7,925		7,925		5.1
3,375		3,375		5.2
20		20		5.3
0.24		0.28		5.4
0.50		0.50		5.5
360	282	360	323	5.6
36	45	33	47	5.7
wet disc brakes		wet disc brakes		5.8
Cummins		Cummins		5.9
QSM 11		QSM 11		6.0
224 (300HP)		224 (300HP)		6.1
1,800 - 2,100		1,800 - 2,100		6.2
6	10,800	6	10,800	6.3
19		19		6.4
Automatic 4-speed		Automatic 4-speed		6.5
245		245		6.6
90		90		6.7
73		73		6.8
no		no		6.9

WHEELS & TYRES CHARACTERISTICS WEIGHTS DIMENSIONS PERFORMANCE ENGINE OTHERS

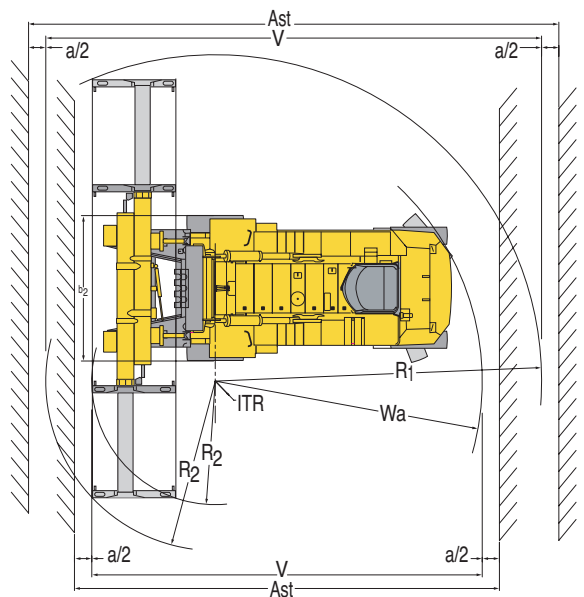
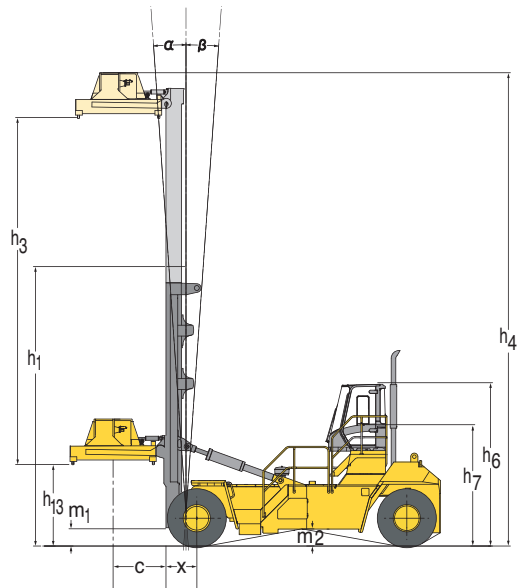

- $r_1$  = radius of swing of container rear corner
- $r_2$  = radius of swing of container front corner
- $W_a$  = outside turning radius of the truck
- $a$  = total operating clearance,  $a/2$  is operating clearance at each side
- $a$  = 10% of  $V$
- $V$  = (theoretical) 90° stacking aisle width, no intrusive stacking  
=  $r_2$  + the larger of  $r_1$  or  $W_a$
- $Ast$  = (practical) 90° stacking aisle, no intrusive stacking and with clearance  
=  $V + a = V + 10\%$

† Drawbar pull performance figures are only indicative for comparison purpose. These performances are only possible for a short period of time.

All specifications and capacities quoted in the mast and capacity information tables are valid for trucks equipped with a Hyster container handling attachment and for handling ISO containers, which are 8' wide and 8'6" - 9'6" high.

Hyster products are subject to change without notice. Lift trucks illustrated may feature optional equipment. The capacities quoted are in conformance with standards ISO 1074 and 10525.

**CE Safety:** This truck conforms to the current EU requirements.



## New Features, Proven Components

The H40.00-50.00XM-16CH range of dedicated container handlers is the 5th generation of a proven machine. These trucks build on more than 40 years of Hyster experience in providing solutions to the container handling industry.

### New Features

- › Container handlers equipped with a mast are receiving renewed interest from terminal operators, because these 'first row container stackers' perform container shunting operations faster than most reachstackers.
- › The 'masted' Hyster H40.00-50.00XM-16CH trucks represent a refreshing new concept, purposely developed to deliver these high 'box-rates' in first row stacking operations, at the lowest possible operational costs.
- › The location of the operator compartment – towards the rear of the machine - is unique and unconventional.
- › Although well accepted on empty container handlers, Hyster is the first manufacturer to apply the rear-mounted cab concept for laden container handlers, as it provides truly excellent all round visibility.

- › The key benefit of this layout is that any obstruction to the operator's forward visibility is greatly reduced. Forward visibility is comparable to most reachstackers. Rearward visibility is outstanding.

### Familiar Features

- › The H40.00-50.00XM-16CH series of 'first row container stackers' have been developed using the experiences gained through the manufacture to-date of over 1000 Hyster 'masted' container handlers.
- › Constructed using proven components – The new machine features the chassis and the complete drivetrain of the Hyster ReachStacker
- › The Hyster designed 'Vista' mast, the supremely simple Dedicated Carriage and the container spreader are proven components, as featured on hundreds of Hyster container handlers, which have been in operation for many years.
- › The machine features the Hyster 'Vista' Operator compartment, as offered on other Hyster products. It has industry-leading ergonomics, and provides superior driver comfort and excellent all-round visibility.



### Visibility

- › The rear-mounted cab position offers an optimum level of all-round visibility that is unique in this product segment.
- › The driver is able to maintain a complete 40ft container in his line of sight, during the entire handling operation with minimal head movement.
- › The driver has an excellent view of the job at hand, not only thanks to the cab position itself, but also the extensive glass area and the position of the dash display (mounted on the right hand side). Upward visibility is also virtually free from obstruction, thanks to a clever overhead guard design.
- › The 'Vista' mast has extremely wide-spaced channels (350 mm more than on the previous model) that allow for greater visibility.

### Performance

Fast, economic handling is the prime benefit of the new Hyster 'first row stacker' container handler.

- › Due to the simplicity of the 'straight lift' mast movement and high lifting speeds, these container-handling machines perform 'container-shunting' operations faster than most reachstacker type machines.

- › Fastest spreader (dis)engagement to/from containers is enhanced by the spreader's floating twistlocks, free mechanical articulation and sideshift movement. Automatic twistlock locking, the lift- and over-lowering inhibitor and spreader rotation and reach are all important standard features that help boost productivity.
- › Automotive driving layout and logical joystick type combi-control help the driver to sustain a high performance level.
- › Endurance is also provided through the truck's cooling system that is suitable up to 50°C ambient temperature.

# Mast and Capacity Information

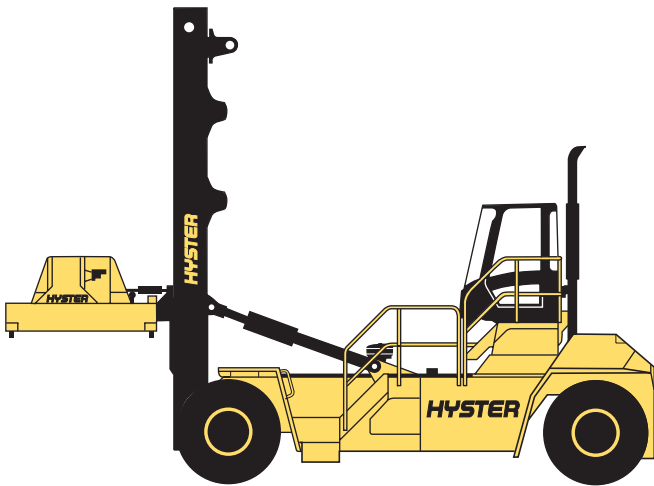

## Capacity (kg) with high-mounted DEDICATED 20'-40' telescopic container spreader

	Stacking height & container height	Recomm. Mast lift height BOF (mm)	Mast lowered height (mm)	Maximum under twistlocks (mm)	H40.00XM-16CH	H44.00XM-16CH	H48.00XM-16CH	H50.00XM-16CH
					spreader reach retracted/extended	spreader reach retracted/extended	spreader reach retracted/extended	spreader reach retracted/extended
3 HIGH	8'6"	7010	6476	9290	37100 / 33400	39900 / 35950	40000 / 40000	N/A
	9'6"							
4 HIGH	8'6"	9755	7847	12035	35300 / 31750	39300 / 35400	40000 / 39590	40000 / 40000*
	9'6"							
5 HIGH	8'6"	12650	9332	14930	N/A	N/A	38340 / 35310*	40000 / 40000*
	9'6"							

\*5-High mast and the H50.00XM-16CH are with: Heavy Duty mast and 30 mm extra load distance on dedicated carriage

- Stacking heights up to 5-high 9'6" containers.
- Ability to stack up to 40 tonne containers.
- Hyster 2-stage 'Vista' mast has large channel overlaps to ensure excellent strength and durability and to minimize flexing during stacking.
- Wide mast and front axle (350 mm wider than former model) gives immensely improved forwards visibility and added sideways stability for stacking heights up to 5-high 9'6" containers.
- Uniquely simple routing of the hydraulic functions over the mast to the spreader, by only two hoses and two cables.





## Drivetrain

### Engine

- › Cummins QSM 11 6-cylinder diesel engine conforming to EU Tier 3 exhaust emission requirements for NRRM (Non-Road Mobile Machinery).
- › Turbo-intercooler engine delivering 224 kW (300 Hp) at 1800 - 2100 rpm.
- › Very smooth torque characteristic, with max. 1424 Nm between 1000-1400 rpm, resulting in excellent lifting and acceleration power, combined with low fuel consumption.
- › Engine protection system, with shutdown function on high coolant temperature and/or low oil pressure.
- › Heavy-duty air cleaner, with two-stage filter plus a cyclonic pre-cleaner, suitable for dusty operating environments.
- › Cooling system suitable up to 50°C ambient.
- › Fuel Tank: 700 litres.

### Transmission

- › The S.O.H. model TE-27 powershift transmission has fully automatic 'APC200' soft-shift 4-speed gear change and an electronic 'inching' function, plus a protective lock-out, to help prevent forward to reverse shifting while on the move.
- › Back-up alarm sounds when in reverse gear.

### Axles

- › Drive axle with double reduction and one-piece drive shafts, with multiple wet disc brakes with cooling system.

### Brakes

- › Service brakes: Oil cooled, multiple wet disc brakes on the front wheels, hydraulically charged by accumulator, with cooling system.
- › Parking brake: Spring actuated and hydraulically released, acting on the drive shaft. Parking brake is automatically applied when hydraulic pressure falls below 100 bar.
- › Steer axle with single steering cylinder and non-adjustable tie-rods. Wheel nut protection.
- › 18.00 x 25 wheels fitted all-round.

## Hydraulic System

- › Three heavy-duty gear pumps, supplying 430 l/min.
- › Leak free ORFS type hydraulic fittings.
- › Filtration:
  - Two fulltime, full flow 10 micron return line hydraulic filters
  - Two 150 micron suction-filters, high pressure 20 micron filter to protect sensitive parts of the hydraulic system,
  - 10 micron air-breathers with indicator on the hydraulic tank.
  - Hydraulic tank capacity 600 litres.
- › Tropical hydraulic system cooling, suitable up to 50°C ambient.



## Spreader Specifications

Hyster 20'-40' Telescopic top lift spreader for handling ISO containers with a height of 8' to 9'6", features:

- › Pendular floating ISO twistlocks.
- › Automatic twistlock locking (manual locking also possible). Unlocking is done manually.
- › 434 mm total sideshift - 217 mm each side.
- › 5° Free mechanical sideways articulation (horizontal self-levelling).
- › 9° Hydraulic powered slew (4.5° each side) or 210 mm of forward / backwards reach movement.
- › Twistlock indicator flags on the spreader corners.
- › Twistlock indicator lights in the cab, and on the spreader.
- › Twistlock lock-out device, built into the spreader, to help prevent:
  - engaging a container by less than 4 corners,
  - unlocking when carrying a container.
- › Lift interrupt system, to prevent lifting a container with partially turned twistlocks
- › Anti-slack function to help prevent the mast over-lowering / the lift chains slackening.
- › 'Gather guides' near the two rear twistlocks, for easier spreader engagement.
- › 4 Lifting eyes, on the 4 corners of the end-beams of the telescopic container spreader, for lifting general cargo.
- › 2 Wide-beam work lights on the spreader, pointed to the rear twistlocks







## Operator Compartment

**Hyster 'Vista' cab with industry leading comfort and visibility.**

### Comfort

- › Air conditioning with manual temperature control.
- › Filtered fresh air inlet.
- › Heater device with 3-stage blower.
- › Spacious rubber floored, easy to clean, operator compartment. Mounted on anti-vibration isolators.
- › Low noise level of only 73 dB(A) LEQ at drivers ear.
- › Fully adjustable suspension seat with armrests, high backrest and safety belt. (Optional: Air-suspension seat).
- › Sliding windows in cab doors.
- › Door locking device while driving with the doors open.

### Controls

- › Seat mounted console with joystick.
- › Joystick control for lift, tilt and spreader functions - sideshift, rotation / slewing and reach / retract. (twistlock locking is automatic).  
Functions operated by separate toggle switches are spreader telescoping and twistlock unlocking.
- › Directional lever with forward / reverse shifting protection.
- › Auto-shift function (manual shifting possible).
- › Finger light steering. Steering column adjustable in height and angle. Small steering wheel with spinner knob.
- › Responsive hydraulic brakes and automotive style pedal layout.



### Visibility

- › Extensive glass area. Lightly tinted glass.
- › Clever overhead guard design.
- › Effective hot air demister system with various outlets.
- › Wipers and washers on front, top and rear window.  
Large front window with effective H-shape twin wipers. Two panorama type rear view mirrors.
- › Spreader indicator lights positioned at the front cab roof.

### Instruments and Controls

- › Conveniently side-positioned dash display with central warning device on steering column.
- › Analogue display for: Hour meter, Fuel level, Battery charge, Engine oil pressure and coolant temperature, Transmission pressure and temperature.
- › Warning lights for: Lights on, Wiper and washer functions, Battery charge, Low brake pressure.
- › Audible warning for: Low brake pressure, Back up alarm when in reverse gear.

### Electrics

- › 24 V system, 70 A alternator, battery 200 Ah (20 hr.)
- › All sealed connectors.
- › Battery master switch.

### Lights

Extensive Light kit, consisting of:

- › 4 front working lights on the cab, halogen, for 20' and 40' positions.
- › 2 rear facing working lights, halogen, on the cab.
- › 2 drive lights and 2 front marker lights.
- › 2 tail and stop lights.
- › 4 direction indicator lights.
- › Orange flashing beacon on the cab.
- › Two wide beam working lights, halogen, on the container spreader.



## Optional Equipment

- › 2-High stacking configuration:
  - Equipped with min. 4270 mm BOF lift height mast (lowered height 5106 mm).
  - Fitted with a 650 mm lower cab position (to enable clear through mast visibility underneath a 2-high raised 9'6" high container).
  - Includes tilting cab for service access.
- › Special paint (RAL) colour(s).
- › Smaller sized 16.00 x 25 rear wheels.
- › Radial type tyres.
- › Central greasing system, on truck and spreader.

### Operator convenience / cab options:

- › Mast tilt indicator (mechanical).
- › Air suspension seat.
- › Without air-conditioning, but with sunshade screens on top and rear window.

### Spreader options:

- › Half-high mounted dedicated carriage & spreader, to also handle 4' and 4'3" half-height containers. A mast with min. 1.22 m more lift height is selected to keep the same total maximum container stacking height.
- › Extra Load Distance of 127mm on a high-mounted dedicated carriage & spreader. The extra distance may facilitate easier handling from/on wide railway wagons.
- › 30' Automatic stop, required for handling (a) 30' container(s).
- › 4 Extra lifting eyes underneath the centre of the spreader. (Note: 4 corner lifting eyes are standard)

## Service Access

- › Engine and transmission check points are directly accessible via two top covers.
- › Engine, transmission and hydraulic components are easily accessible by lifting off the aluminium top covers.
- › Large compartments doors and openings are situated on both sides of the machine.





## Strong Partners, Tough Trucks, for Demanding Operations, Everywhere.

Hyster supplies a complete range of warehouse equipment, IC and electric counterbalanced trucks, container handlers and reach stackers.

Hyster is committed to being much more than a lift truck supplier. Our aim is to offer a complete partnership capable of responding to the full spectrum of materials handling issues:

Whether you need professional consultancy on your fleet management, fully qualified service support, or reliable parts supply, you can depend on Hyster.

Our network of highly trained dealers provides expert, responsive local support. They can offer cost-effective finance packages and introduce effectively managed maintenance programmes to ensure that you get the best possible value. Our business is dealing with your materials handling needs so you can focus on the success of your business today and in the future.



Hyster Europe, Flagship House, Reading Road North, Fleet, Hants GU51 4WD, England.

Tel: +44 (0) 1252 810261

Fax: +44 (0) 1252 770702

Email: [info@hyster.co.uk](mailto:info@hyster.co.uk)

<http://www.hyster.co.uk>

A division of NACCO Materials Handling Limited.

